

# PWM and Tach Output Brushless DC Fan **08080EA-12S (D-Type)**

**NMB**

## General Specifications

### Motor Type:

DC Brushless Three Phase Motor

### Motor Protection:

Auto Restart / Polarity Protection (Motor withstands reverse connection for positive and negative leads.)

### Insulation Resistance:

10MΩ or over with a DC 500V Megger

### Dielectric Withstand Voltage:

AC 700V 1sec or 500V 1min

### Allowable Ambient Temperature Range:

-10°C ~ + 60°C (Operating)  
-40°C ~ + 70°C (Storage)  
(non-condensing environment)



*\*For reference only. Please see fan outline for details*

## Characteristic Curves

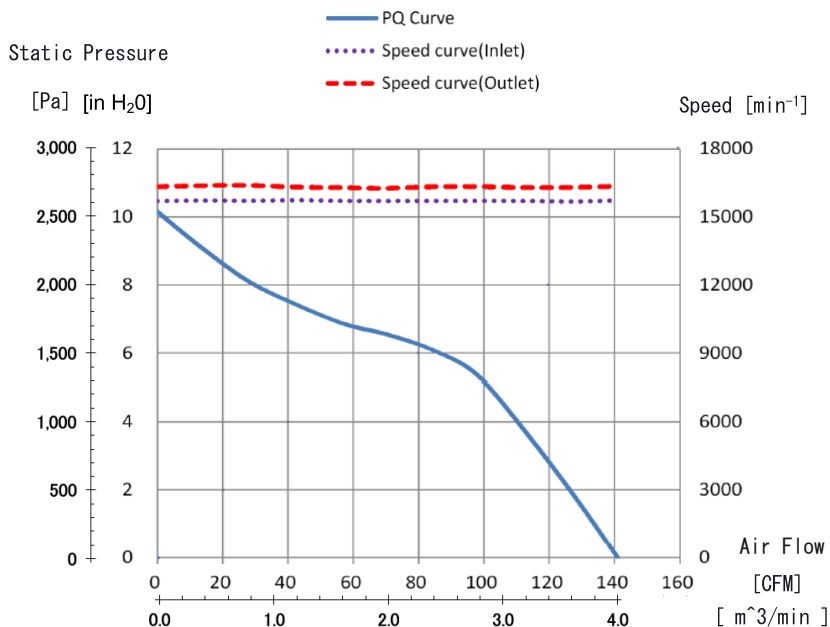

## Features

- High performance counter rotating fan with eight wires and PWM with tach signal
- Efficient motor technology, high torque, and aerodynamic impeller design
- Energy saving, low vibration, and increased life expectancy
- Available in 12 volts with tach output and PWM speed control
- Outfitted with NMB precision machined ball bearings for long life
- Three phase motor design for high speed and efficient cooling

## Life Expectancy L10

70,000 Hours at 40°C

*\*Fan life expectation is based on free air operation at 40°C, rated voltage, and indoor benign lab environment*

*\*1: Values in Free Air*

## Specifications

MODEL	Rating Voltage (V)	Operating Voltage (V)	Current		Input Power		Speed Inlet/Outlet		Max. Air Flow		Max. Static Pressure		Noise (dB) <sup>*1</sup>	Mass (g)
			Avg (A) <sup>*1</sup>	Max (A) <sup>*1</sup>	Avg (W) <sup>*1</sup>	Max (W) <sup>*1</sup>	RPM		(CFM)	(m <sup>3</sup> /min)	(in H <sub>2</sub> O)	(Pa)		
08080EA-12S-E6D-2	12	10.8 to 13.2	8.0	9.8	96.0	118	15,800/16,300	141	3.99	10.0	2490	79.0	430	

# PWM and Tach Output Brushless DC Fan 08080EA-12S (D-Type)



## PWM Specifications

### Connection

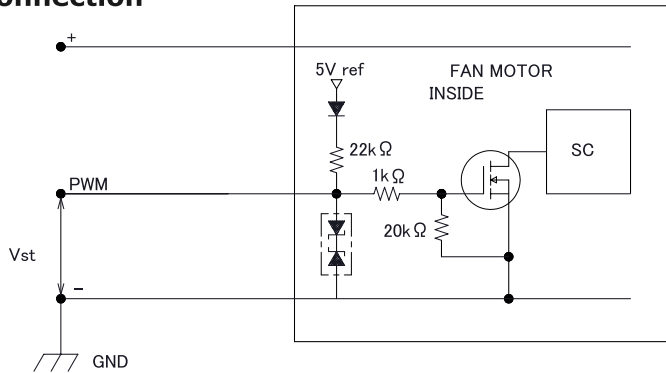

### 1. PWM Control

- $V_{st} = \text{Low Level (0V} \sim \text{0.4V)}$  → Stop (On Duty 0%)
- $V_{st} = \text{High Level (3.0V} \sim \text{5.0V)}$  → Full Speed (On Duty 100%)
- $V_{st} = \text{Open}$  → Full Speed

### 2. PWM Duty & PWM Input Pulse

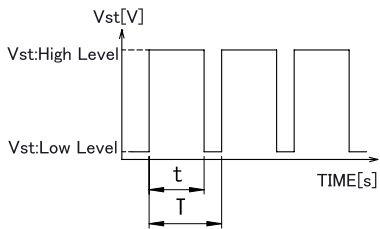

PWM Duty means that a ratio of high level time (t)/PWM Input Pulse(T).

$$(t/T) \times 100 : \text{On Duty } 0\% \sim 100\%$$

$$\text{PWM Frequency } f = 25[\text{kHz}]$$

### 3. The condition for PWM control are as follows

- When you use this under PWM control, always be sure the motor's operation under practical mounting state. Fan motor may not start up caused by PWM control at very low speed condition.)
- To run at Rating Voltage
- Please use the start with Duty 20% or more at 25kHz.[At rated voltage input, Ambient temperature 25°C]

## TACHO Specifications

### Tachometer Signal

OUTPUT CIRCUIT : OPEN COLLECTOR SPECIFICATION

Absolute Maximum Ratings at  $T_a=25^\circ\text{C}$

$V_{CE \text{ max}} : +15\text{V}$

$I_c \text{ max} : 5\text{mA}$  [ $V_{CE(\text{sat})\text{max}} = 1.0\text{V}$ ]

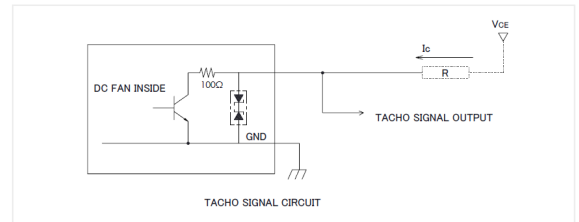

### 3. Output Waveform: At Rated Voltage Output Signal Voltage

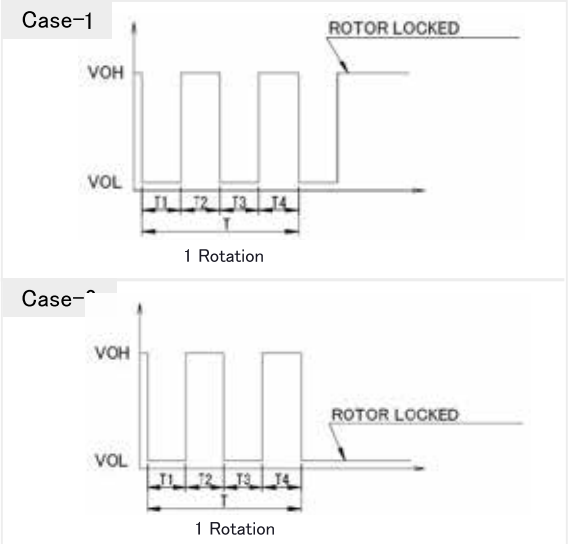

- 1) When the rotor is locked at VOH position of signal, signal keeps VOH position.
- 2) When the rotor is locked at VOL position of signal, signal keeps VOL position.
- 3)  $T = T_1 + T_2 + T_3 + T_4 = 60/m = 1 \text{ rotation}$   
 $m : \text{Fan Speed (min}^{-1}\text{)}$   
 $\text{Tacho Duty Cycle} = 50\% \pm 10\%$

## PWM Characteristic Curve

PWM Duty vs Speed Curve  
<Reference Value>

Conditions : At Rating Voltage,  $V_{st(H)}=5\text{V}$ ,  $f=25\text{kHz}$ ,  $T_a=25 \text{ Celsius}$

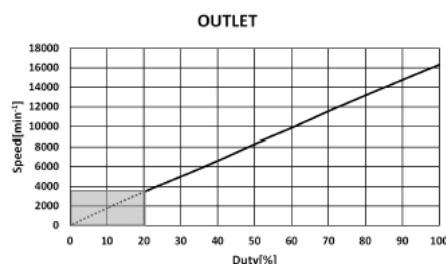
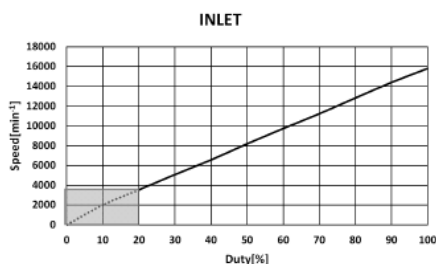

# PWM and Tach Output Brushless DC Fan

## 08080EA-12S (D-Type)

NMB

### Outlines

(Name Plate)

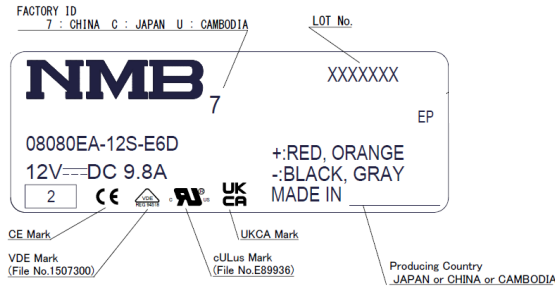

### Materials

**Casing:** Plastic (Black UL94V-0)

**Impeller:** Plastic (Black UL94V-0)

**Bearing:** Steel Ball Bearing

**Lead Wire:** UL10368, AWG20 for Red, Black, Orange, and Gray

UL10368, AWG26 for White, Brown, Yellow, and Blue

[INLET FAN]

(+)/Red  
 (-)/Black  
 (TACH)/White  
 (PWM)/Brown

[OUTLET FAN]

(+)/Orange  
 (-)/Gray  
 (TACH)/Yellow  
 (PWM)/Blue

(Outline)

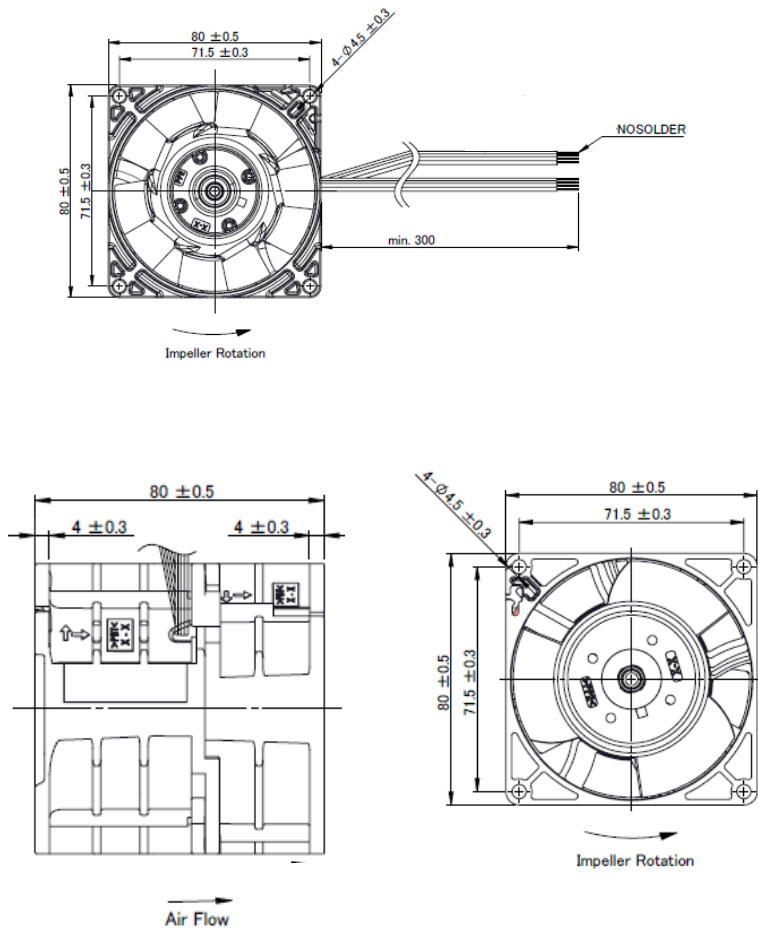

(Panel Out-line)

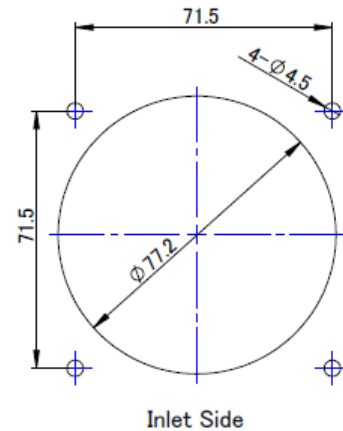

Inlet Side

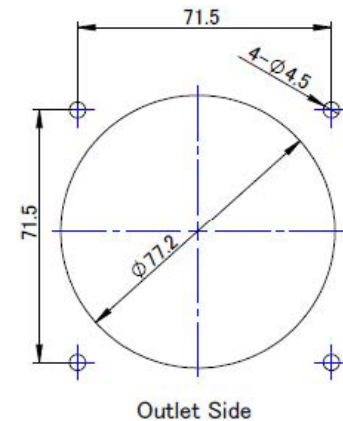

Outlet Side